

RADAR TRANSPONDER

COURSE

Serial No _____

OWNER'S MANUAL

Contents

1. General instructions	3
2. General information about RT	3
3. The operation manual	4
4. Information about maintenance	4
5. Main technical information	6
5.1. Technical specification	6
5.2. Check parameters	7
6. Completeness of set	7
7. Acceptance certificate	8
8. Packing Certificate	8
9. Manufacturer's guarantees	8
10. Information about claims	9
11. Information about storage	9
12. Technical examination of Radar Transponder by special control bodies	10
13. Information about batteries installation	11
14. Special notes	12
Appendixes. Pictures:	
General view of the Radar Transponder	13
Console	14
Arm	15

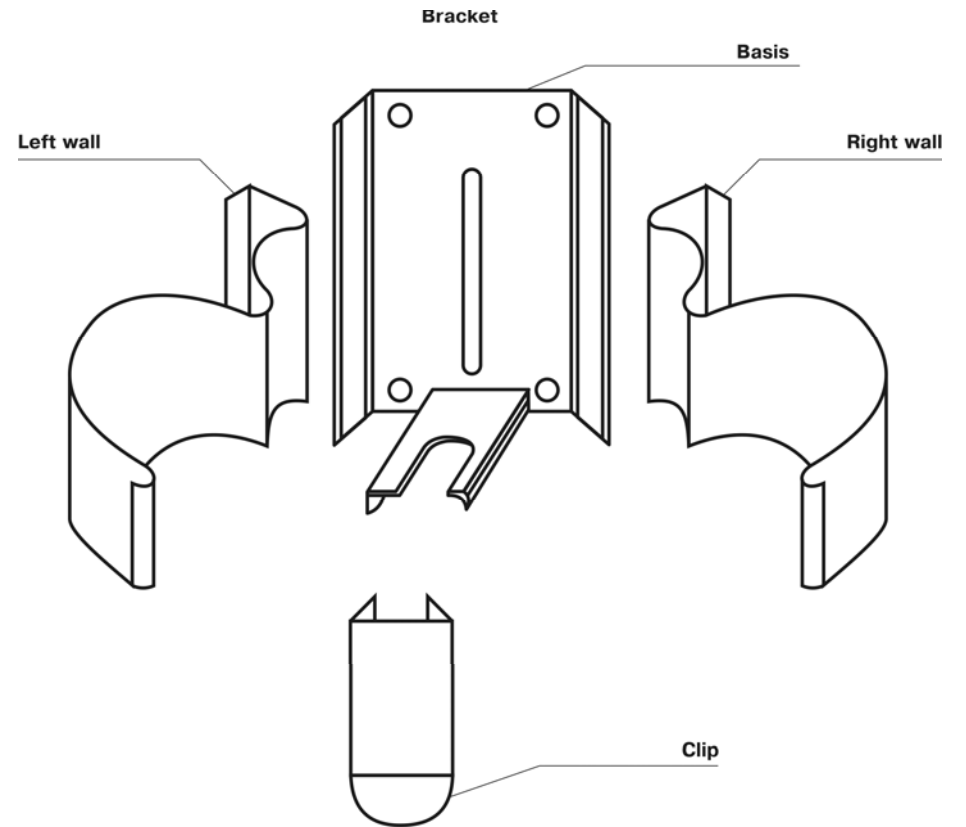

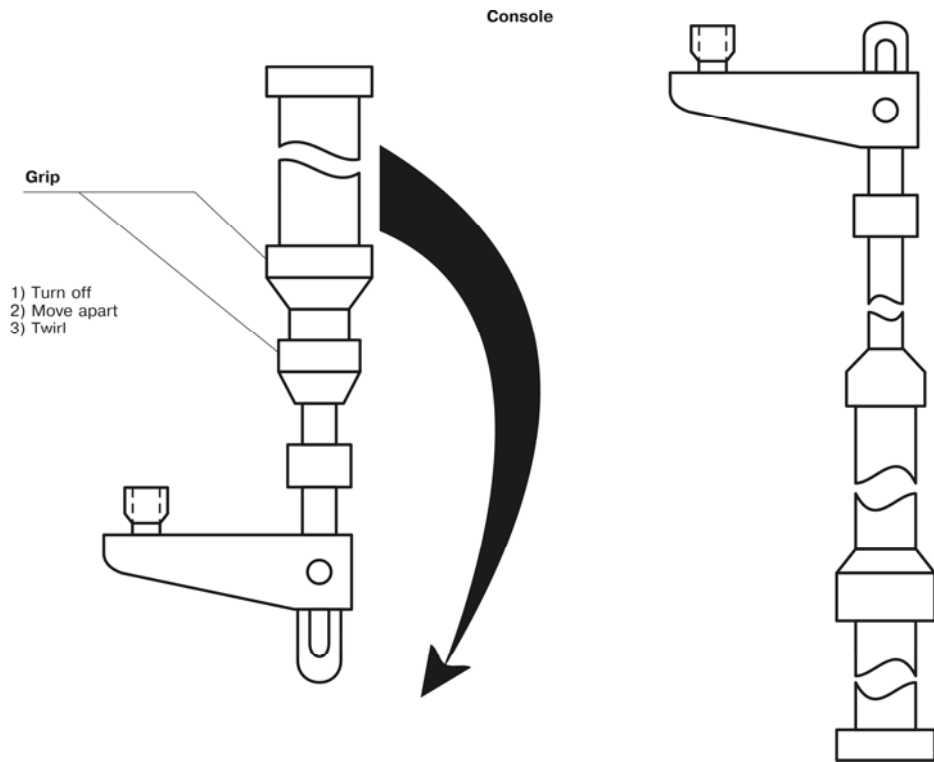

1. General instructions

1.1 Before operation it is necessary to familiarize attentively with the instructions stated in the present data card.

1.2 This Data card is included into the complete set of the Radar Transponder "Course" (further - RT) and should be permanently with it.

1.3 All records in the data card are to be made only ink, distinctly and neatly.

1.4 This Data card is a document reflecting technical condition of RT and containing the information about its operation.

1.5 Sections 5.2, 7, 8 are filled by the manufacturer. Section 12 is filled by inspecting services. In section 13 the first record about batteries installation is made at Manufacturer.

2. General information about RT

2.1 Radar Transponder "Course" is intended for definition by signaling of site of the object in distress. This signals will be presented on the screen of radar stations of X-band (further - radars) by series of arcs (two arcs) or points (two points), equally spaced towards range increase. The nearest point by range is the site of the object with RT. Radar Transponder "Course" concerns to a portable category of the equipment.

RT are installed on vessels, rescue facilities and other objects and they are putted in action in the time of disaster.

2.2 RT is water-proof on depth not more than 10 m. during 5 minutes. It has positive buoyancy without arm and it can be dropped on water from height not more than 20 m.

2.3 RT power supply comes from two chemical batteries type ER 34615M. It is necessary to co-ordinate with RT Manufacturer the application possibility of the other type of batteries. The batteries are installed in RT during its putting into operation. During RT storage, the batteries are stored separately.

2.4 RT is delivered in completeness specified in table 6.

2.5 The interval of RT operating temperatures is starting with 253 till 328 K (from minus 20 to 55 Celsius). RT meets the requirements resolutions IMO A.530 (13), A.694 (17), A.802 (19), recommendations IEC № 61097 - 1, IEC № 60945-02, ITU-RM.628-4.

3. The operation manual.

3.1 With the help of arm RT is installed on the bulkhead in internal vessel premises larboard and astarboard in immediate proximity to the exit in conning bridge or upper deck at not less than 1 m from compass.

3.2 The Arm is intended for protection of RT against unintended switching on and for fastening on vessel bulkhead. After its installation, the arm is to be sealed.

3.3 At accident of the vessel, RT should be removed from the arm and installed at the rescue facility (boat or raft) in the proper place. The RT is supplied by the console intended for RT keeping in hands on the rescue facility – raft or boat. By impossibility of RT installation in the proper place, or impossibility of RT keeping in hands, it shall be fixed at maximum possible height, but not less than 1 m above-sea level so that it would be not shaded by metal parts of watercraft.

3.4 RT is switched on by turning the switch in position «ON» after installation on watercraft preliminary having removed the control tape. The indicating light flashes on. If RT is situated in the emission zone of the search vehicle radar, the indicating light starts to blink

3.5 RT is supplied by the brief instruction about putting into operation in English placed on the product nameplate.

4. Information about maintenance

4.1 Maintenance service of RT consists of external examination, functional testing and schedule replacement of batteries.

4.1.1 External examination of RT includes check on absence of mechanical damages, presence of records on the RT nameplate about the date of the next batteries replacement and check on seal presence.

4.1.2 Functional testing of RT consists in check of joint action of RT with vessel radar and device for RT testing. Functional testing of RT is carrying out not less than once in a year, and also after batteries replacement.

4.1.3 Term of operation of elements of a feed 5 years from the moment of installation in SART within the limits of a warranty period of storage.

4.2 Testing of RT action with vessel radar:

Remove the seal on RT arm. Take RT from the arm and switch it on removing the control tape and turning the switch in position «ON». Check constant luminescence of the light indicator. RT is ready to work with radar. Switch off RT by turning the switch in position «OFF», the light indicator will go out. Provide a distance of five miles between RT and antenna of vessel radar. During the testing of RT action with radar keep RT

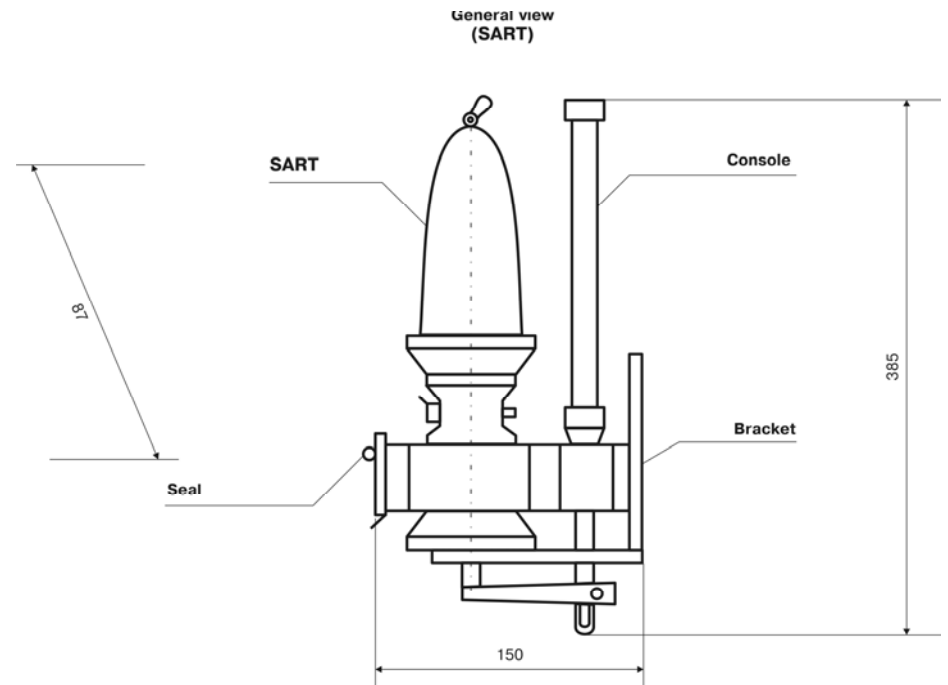

14. Special notes

upright overhead. Switch on the vessel radar and RT. By illumination of RT with X-waveband, the indicating light of RT stops to light up and starts to blink. On the radar screen are highlighted the replies from RT in form of arcs (two arcs).

For supervision of all twelve replies of RT it is necessary to pass to the big range scale of the radar screen.

The distance on the radar screen between first and twelfth RT signal is not more than 10 miles. The distance to the object with RT on the radar screen is defined by the first (nearest) reply.

As may be agreed with harbour authorities, it is permitted to make the RT functional testing in harbour, having installed it on the beach, in radar visibility range. But the part of replies can not be observed because of disturbances.

To save the battery capacity of RT and not to create disturbances to other working radars this testing should be made within several seconds.

4.2.1. The testing of RT by test device for RT testing is carrying out according to the technical description of the device.

4.2.2 Battery replacement.

Remove the seal on the arm, remove a clip following the arrow, take out RT from the arm, remove console, having turned off it counterclockwise. Turn off 6 screws of the bottom cover, remove the rubber gasket and turn off 6 screws of the batteries fastening plate. Take out batteries from the sockets of power unit.

Install new batteries according to polarity. Install all the parts in reverse sequence. Check up functionality of RT according to the procedure specified in clause 4.2.

Install RT into arm and seal it.

During the initial battery installation or replacement put the date of their next replacement on the frame of RT.

RT it is maintainable in the service centers certificated by the manufacturer.

Remark. Protect the electronics against blows, do not put on current-conducting surface, contacts of circuit plates and do not close.

Attention! Lithium cells used in RT are high-risk objects. During the work with the batteries the following is forbidden:

To make short circuit;

To heat up over 70 Celsius;

To break the installation polarity in RT;

To store used elements in not designated places.

5. Main technical information.

5.1 Technical specification

Name of the parameter and unit measure	Rated value
1. Frequency band of the emitting signal, within the range, MHz	9200 – 9500
2. Polarization	horizontal
3. Rate of frequency tuning in the reply	(200 ± 20) MHz for 5 µs
4. Quantity of frequency tuning in the emitting signal	12
5. Form of frequency tuning, µs	
- forward trace;	7,5 ± 1
- reverse trace.	0,4 ± 0,1
6. Width of emitting reply pulse, µs	81,6 - 108
7. Effective emitting power, not less, mW	400 (+ 26 dBm)
8. Effective receiver sensitivity, not worse, dBm	minus 50 dBm (0,1 mW/m ²) Note 1
9. Operation time, hour:	
- standby conditions;	96
- transmission mode: being continuously interrogated by pulse frequency 1 kHz	8
10. Temperature range, °C	
- working;	minus 20 + 55
- storage.	minus 30 + 65
11. Restoration time of receiver sensitivity, not more, µs	10
12. Delay time of emitting signal relative to interrogation pulse, not more, µs	0,5
13. Antenna height, not less, m	1 (Note 2)
14. Antenna beam, dB:	
- vertical;	± 12,5 ⁰
- azimuth: omnidirectional.	± 2

Note:

- 1) Effective receiver sensitivity includes the sensitivity of antenna.
- 2) Effective antenna height concerns the equipment demanded by section 6.2.2 from the Chapter III and 7.1.3 and 8.3.1 from Chapter IV 1988 of Amendments to Convention SOLAS 1974.

13. Information about batteries installation

Type of installed elements	Date of the next replacement of elements	Position, surname and the signature of the person who have carried out the replacement	Date of making the record

12. Technical examination of Radar Transponder by special control bodies

Examination date	Examination results	Date of the next examination	Position, surname and the signature of the representative of control body

5.2 Check parameters.

Name and unit measure	Parameter value			Notes
	Technical requirements		Actual	
	Rated	Limit deviation, permissible measurement error		
1. Effective emitting power, not less, mW	400	12%		
2. Frequency band of the emitting signal, within the range, MHz	9200 9500	minus 60 +60		
3. Width of emitting reply pulse, μ s	81,6 - 108			
4. Quantity of frequency tuning in the emitting signal	12			

6. Completeness of set

6.1 RT Completeness of set:

Name	Quantity	Overall dimensions, not more, mm	Mass, not more, kg	Note
1. Radar Transponder "Course" in structure:	1	385x160x107	1,34	
- SART "Course"	1	height 370 diameter 87	0,93	
- Arm	1	160x125x107	0,2	
- Console	1	385x85x35	0,21	
2. The complete set spare parts:	1			
- safety lock БП-1-1-2А	1			
- control tape	4			
- lanyard	1	10 m		
3. Owner's manual	1			

7. Acceptance certificate.

Radar Transponder "Course"

Serial number _____ meets technical requirements and is recognized as ready for operation.

Production date « ___ » _____ 20 ____

_____ personal signatures (personal stamps impressions) of the enterprise officials

_____ who are responsible for product acceptance

Stamp here

8. Packing certificate

Radar Transponder "Course"

Serial number _____

was packed on _____ *SPDE "Musson-Morsviaz-Service"* _____
(name and code of the enterprise making packing)

according to the requirements provided by the design documentation.

Packing date _____

Packing was made by _____
(Signature)

Packing was accepted by _____
(Signature)

9. Manufacturer's guarantees

9.1 Manufacturer guarantees the conformity of RT parameters to technical requirements if the consumer keeps the operation, transportation and storage conditions specified in documents of RT.

9.2 Warranty lifetime of RT makes 2 years from the date of sale.

9.3 Batteries are products of single delivery, their refusal should not be considered as refusal of RT

10. Information about claims

10.1 RT will be subject to claims only when the refusal or discrepancy to technical requirements will be found out before the expiration of a warranty period if storage, transportation, installation and operational regulations was kept.

10.2 The claim about RT rejection should be sent on the address of the manufacturer's director.

11. Information about storage

RT should be kept in packing at temperature from minus 30°C up to + 65°C in the room protected from penetration into him of an atmospheric precipitation, without sharp fluctuations of temperature and humidity.